

Brief Instructions



Sensor field

1. Display
2. On/off
3. Heating Functions or Assisted Cooking menu
4. Home Key
5. Temperature selection
6. Microwave function
7. Up key
8. Down key
9. Time and additional functions
10. Minute Minder
11. OK/Microwave Quick Start

On/off

Press once - activates the appliance.

Heating Functions Assisted Cooking

Press once or twice - activates a Heating Function or an Assisted Cooking function.
Press and hold for 3 seconds - activates or deactivates the oven lamp.

Fast Heat Up

Press once - checks the temperature when the appliance operates. Press and hold for 3 seconds to activate or deactivate the Fast Heat Up function.

Microwave function

Press once - activates the Microwave function. You can also use it after you deactivate the appliance.

OK/Microwave Quick Start

Press once - activates Microwave Quick Start function. If you press it when Microwave operates it increases time by 30 sec.

Home Key

Press once - goes back one level in the menu. Press and hold for 3 seconds to show the main menu.



Thinking of you
Electrolux



Press once

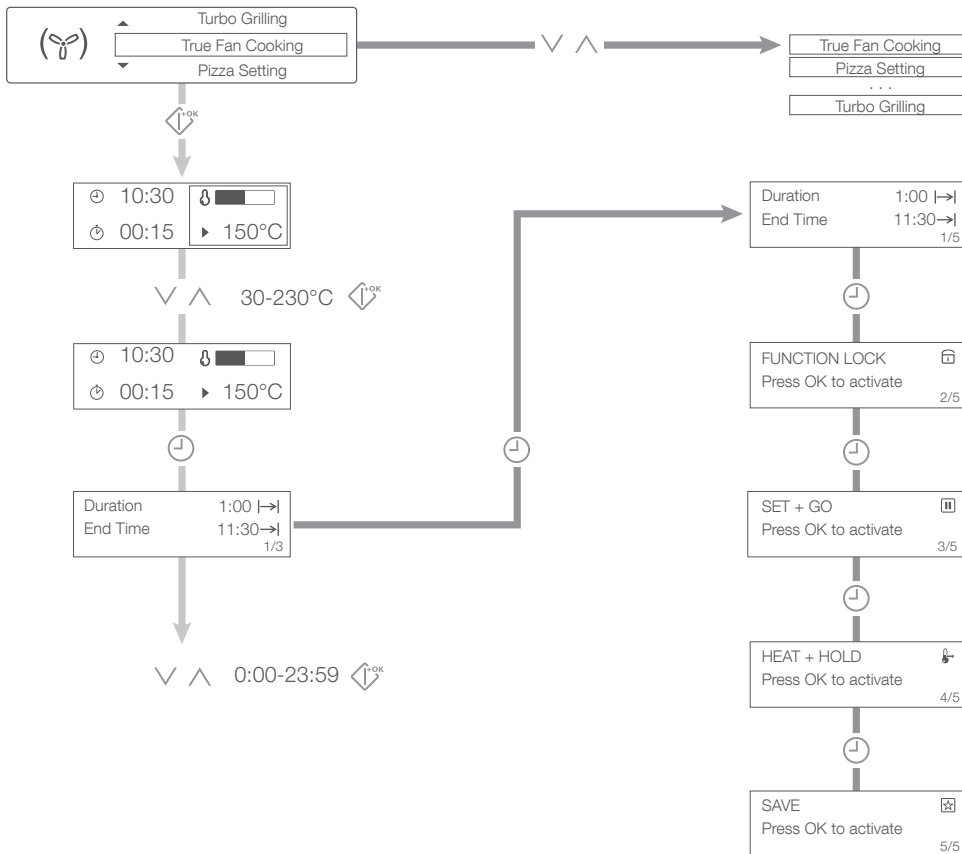

Microwave Combi - Oven

Heating Functions:

True Fan Cooking

Pizza Setting

Conventional Cooking

Slow Cook

Bottom Heat

ECO Roasting

Frozen Foods

Grilling

Fast Grilling

Turbo Grilling

Specials:

Bread Baking

Au Gratin

Dough Proving

Plate Warming

Preserving

Drying

Keep Warm

Defrost



Press twice

3s

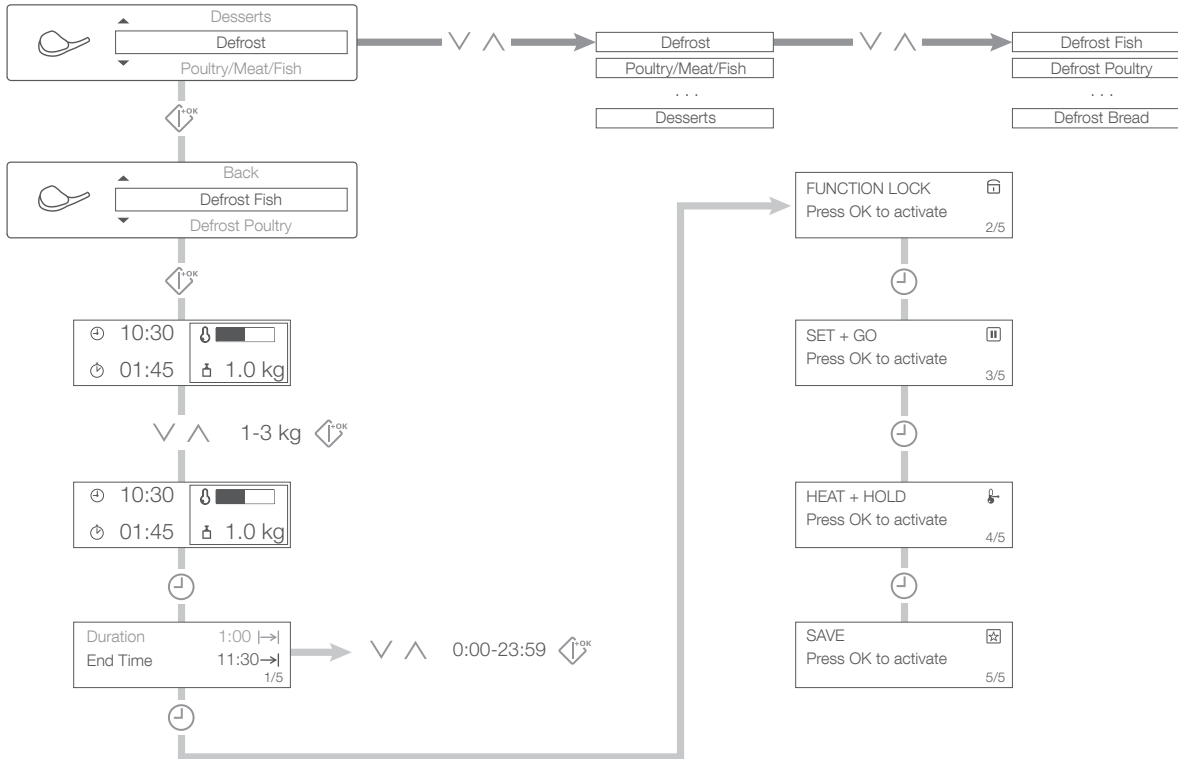



Microwave Combi - Oven

Defrost

Defrost Fish
Defrost Poultry
Defrost Meat
Defrost Bread

Cooking/Melting

Fresh Vegetables
Frozen Vegetables
Braise Onions
Potatoes in their Jacket
Rice
Melting Chocolate
Melting Butter

Poultry/Meat/Fish

Chicken Wings
Chicken, 2 half
Lemon sole rolls
Meat Loaf with Herbes
Fish fillet in Cream Sauce
Chicken Legs
Coq Au Vin
Leg of Lamb
Ossobuco

Steamed Fish
Fillet of Fish
Fillet of Fish, frozen
Mustard Rabbit
Rabbit
Roast Duck with Orange
Stuffed Chicken
Veal Knuckle
Wild Boar
Chicken, whole
Braised meat
Roast Game
Roast Lamb
Roast Pork
Roast Veal
Duck, whole
Goose, whole
Turkey, whole

Pie/Casserole/Gratin

Stuffed mushrooms
Stuffed tomatoes
Vegetable spaetzle
Potato courgette gratin
Cheese gratin
Leek Casserole
Stuffed cannelloni
Potato Gratin

Biscuit
Brownies
Rich Yeast Plait
Carrot Cake
Cheese Flan
Cheese Pastry
Farmer Bread
Lemon Sponge Cake
Muffins
Onion Tart
Pasta Gratin
Pizza
Quiche Lorraine
Ring Cake
Sweet Tart
White Bread
Yeast Plait
Almond Cake
Apple Strudel, frozen
Bread/Rolls
Bread/Rolls, frozen
Beef Casserole
Cheese Cake
French Fries
Fruit Cake
Fruit Tart
Hash Browns
Lasagne
Lasagne/Cannelloni, frozen
Moussaka

Pizza American, frozen
Pizza, chilled
Pizza, frozen
Pizza Snacks, frozen
Pierogi
Savarin Cake
Streusel Cake
Swedish Cake
Wedges/Croquettes
Grandmas RoastApple Cake
Franconian Dumpling Pan
Swedish Festive Roast

Desserts

Apricot cream
Amaretto-peaches